

NIPPLES, TBE, PVC SCH80



PVC SCH80 Nipples

PVC SCH80	1/8"		1/4"		3/8"		1/2"		3/4"		1"		1-1/4"	
	Part Number	List Price	Part Number	List Price	Part Number	List Price	Part Number	List Price	Part Number	List Price	Part Number	List Price	Part Number	List Price
Close	9-5966	\$0.80	9-5997	\$0.80	9-6028	\$0.80	9-6059	\$0.90	9-6090	\$1.00	9-6121	\$1.30	9-6151	\$1.80
1-1/2" Long	9-5967	1.00	9-5998	0.80	9-6029	0.80	9-6060	0.90	9-6091	1.00				
2" Long	9-5968	1.10	9-5999	0.80	9-6030	1.00	9-6061	1.00	9-6092	1.00	9-6122	1.40	9-6152	1.90
2-1/2" Long	9-5969	1.10	9-6000	1.20	9-6031	1.30	9-6062	1.00	9-6093	1.10	9-6123	1.50	9-6153	1.90
3" Long	9-5970	1.10	9-6001	1.20	9-6032	1.30	9-6063	1.10	9-6094	1.10	9-6124	1.60	9-6154	2.10
3-1/2" Long	9-5971	1.30	9-6002	1.60	9-6033	1.90	9-6064	1.10	9-6095	1.20	9-6125	1.70	9-6155	2.40
4" Long	9-5972	1.30	9-6003	1.60	9-6034	1.90	9-6065	1.20	9-6096	1.30	9-6126	1.80	9-6156	2.40
4-1/2" Long	9-5973	1.40	9-6004	1.90	9-6035	2.00	9-6066	1.30	9-6097	1.50	9-6127	2.00	9-6157	2.80
5" Long	9-5974	1.40	9-6005	1.90	9-6036	2.00	9-6067	1.40	9-6098	1.50	9-6128	2.20	9-6158	2.80
5-1/2" Long	9-5975	1.60	9-6006	2.00	9-6037	2.20	9-6068	1.40	9-6099	1.60	9-6129	2.40	9-6159	3.10
6" Long	9-5976	1.60	9-6007	2.00	9-6038	2.20	9-6069	1.50	9-6100	1.80	9-6130	2.50	9-6160	3.10
7" Long	9-5977	1.90	9-6008	2.10	9-6039	2.30	9-6070	1.70	9-6101	1.90	9-6131	2.70	9-6161	3.50
8" Long	9-5978	2.10	9-6009	2.20	9-6040	2.50	9-6071	1.80	9-6102	2.10	9-6132	2.90	9-6162	3.70
9" Long	9-5979	2.20	9-6010	2.40	9-6041	2.70	9-6072	1.90	9-6103	2.20	9-6133	3.30	9-6163	4.00
10" Long	9-5980	2.50	9-6011	2.40	9-6042	2.80	9-6073	2.00	9-6104	2.40	9-6134	3.40	9-6164	4.30
11" Long	9-5981	2.80	9-6012	2.60	9-6043	2.90	9-6074	2.10	9-6105	2.60	9-6135	3.70	9-6165	4.60
12" Long	9-5982	2.80	9-6013	2.70	9-6044	3.10	9-6075	2.20	9-6106	2.70	9-6136	4.00	9-6166	4.90
13" Long	9-5983	3.60	9-6014	4.00	9-6045	4.40	9-6076	2.50	9-6107	3.00	9-6137	4.60	9-6167	5.60
14" Long	9-5984	3.90	9-6015	4.20	9-6046	4.60	9-6077	2.50	9-6108	3.00	9-6138	4.60	9-6168	5.80
15" Long	9-5985	4.00	9-6016	4.40	9-6047	4.80	9-6078	2.70	9-6109	3.10	9-6139	4.90	9-6169	6.20
16" Long	9-5986	4.10	9-6017	4.40	9-6048	4.90	9-6079	2.80	9-6110	3.40	9-6140	4.90	9-6170	6.40
17" Long	9-5987	4.40	9-6018	4.50	9-6049	5.10	9-6080	3.00	9-6111	3.50	9-6141	5.50	9-6171	7.00
18" Long	9-5988	4.60	9-6019	4.70	9-6050	5.30	9-6081	3.00	9-6112	3.60	9-6142	5.50	9-6172	7.00
19" Long	9-5989	4.80	9-6020	4.70	9-6051	5.40	9-6082	3.30	9-6113	4.00	9-6143	6.00	9-6173	8.50
20" Long	9-5990	5.00	9-6021	4.80	9-6052	5.50	9-6083	3.40	9-6114	4.30	9-6144	6.20	9-6174	8.50
22" Long	9-5991	5.50	9-6022	5.10	9-6053	5.90	9-6084	3.50	9-6115	4.40	9-6145	6.40	9-6175	8.80
24" Long	9-5992	5.50	9-6023	5.40	9-6054	6.10	9-6085	3.70	9-6116	4.60	9-6146	6.50	9-6176	9.00
30" Long	9-5993	8.00	9-6024	7.20	9-6055	8.30	9-6086	4.70	9-6117	6.30	9-6147	9.10	9-6177	11.70
36" Long	9-5994	9.20	9-6025	8.20	9-6056	10.60	9-6087	7.30	9-6118	8.90	9-6148	12.10	9-6178	12.80
42" Long	9-5995	10.50	9-6026	9.80	9-6057	11.90	9-6088	9.70	9-6119	10.20	9-6149	14.80	9-6179	16.20
48" Long	9-5996	11.00	9-6027	10.70	9-6058	13.40	9-6089	10.20	9-6120	11.60	9-6150	15.50	9-6180	16.90

TBE (threaded both ends)

PVC SCH80 Nipples

PVC SCH80	1-1/2"		2"		2-1/2"		3"		4"		6"	
	Part Number	List Price	Part Number	List Price	Part Number	List Price	Part Number	List Price	Part Number	List Price	Part Number	List Price
Close	9-6181	\$2.00	9-6211	\$2.60	9-6240	\$8.80	9-6268	\$10.40	9-6296	\$17.00	9-6323	\$18.70
1-1/2" Long												
2" Long	9-6182	2.20										
2-1/2" Long	9-6183	2.30	9-6212	3.00								
3" Long	9-6184	2.50	9-6213	3.10	9-6241	10.00	9-6269	11.40				
3-1/2" Long	9-6185	2.80	9-6214	3.60	9-6242	11.40	9-6270	13.30	9-6297	17.30		
4" Long	9-6186	2.80	9-6215	3.60	9-6243	11.40	9-6271	13.30	9-6298	17.90		
4-1/2" Long	9-6187	3.30	9-6216	4.30	9-6244	12.90	9-6272	15.20	9-6299	19.30	9-6324	26.50
5" Long	9-6188	3.30	9-6217	4.30	9-6245	12.90	9-6273	15.20	9-6300	20.00	9-6325	29.10
5-1/2" Long	9-6189	3.70	9-6218	4.60	9-6246	14.50	9-6274	17.00	9-6301	21.30	9-6326	31.70
6" Long	9-6190	3.70	9-6219	4.60	9-6247	14.50	9-6275	17.00	9-6302	22.30	9-6327	34.60
7" Long	9-6191	4.00	9-6220	5.60	9-6248	16.80	9-6276	21.30	9-6303	25.30	9-6328	39.70
8" Long	9-6192	4.40	9-6221	5.80	9-6249	17.60	9-6277	21.30	9-6304	27.30	9-6329	45.00
9" Long	9-6193	4.90	9-6222	6.20	9-6250	19.30	9-6278	24.30	9-6305	29.40	9-6330	50.20
10" Long	9-6194	5.20	9-6223	6.70	9-6251	20.30	9-6279	24.30	9-6306	31.40	9-6331	55.70
11" Long	9-6195	5.40	9-6224	7.30	9-6252	23.30	9-6280	28.40	9-6307	35.50	9-6332	60.90
12" Long	9-6196	5.80	9-6225	7.60	9-6253	23.50	9-6281	28.80	9-6308	38.50	9-6333	66.10
13" Long	9-6197	6.50	9-6226	8.50	9-6254	25.30	9-6282	29.90	9-6309	42.50	9-6334	71.30
14" Long	9-6198	6.70	9-6227	8.70	9-6255	26.40	9-6283	30.40	9-6310	43.60	9-6335	76.50
15" Long	9-6199	7.30	9-6228	9.40	9-6256	28.40	9-6284	32.40	9-6311	45.60	9-6336	81.70
16" Long	9-6200	7.60	9-6229	9.80	9-6257	30.40	9-6285	34.40	9-6312	47.60	9-6337	86.90
17" Long	9-6201	8.20	9-6230	10.70	9-6258	30.90	9-6286	36.40	9-6313	48.60	9-6338	92.10
18" Long	9-6202	8.40	9-6231	10.90	9-6259	31.40	9-6287	37.50	9-6314	50.70	9-6339	97.30
19" Long	9-6203	9.90	9-6232	13.10	9-6260	36.90	9-6288	39.50	9-6315	57.70	9-6340	103.20
20" Long	9-6204	10.00	9-6233	13.20	9-6261	37.50	9-6289	45.60	9-6316	60.70	9-6341	107.70
22" Long	9-6205	10.20	9-6234	13.40	9-6262	38.70	9-6290	48.10	9-6317	61.80	9-6342	118.60
24" Long	9-6206	10.60	9-6235	13.60	9-6263	39.50	9-6291	49.20	9-6318	63.80	9-6343	129.00
30" Long	9-6207	14.50	9-6236	17.60	9-6264	48.10	9-6292	60.30	9-6319	81.00	9-6344	160.20
36" Long	9-6208	15.20	9-6237	23.40	9-6265	58.80	9-6293	71.40	9-6320	96.20	9-6345	192.20
42" Long	9-6209	20.30	9-6238	28.40	9-6266	67.90	9-6294	83.50	9-6321	117.50	9-6346	223.40
48" Long	9-6210	21.50	9-6239	30.10	9-6267	73.40	9-6295	93.20	9-6322	125.60	9-6347	254.70

PVC Sch80



TBE (threaded both ends)

Schumacher Irrigation, Inc.

Phone: 402-246-3685 or 800-246-3685

Fax: 402-246-2072

Prices effective January 1, 2012

Section Six

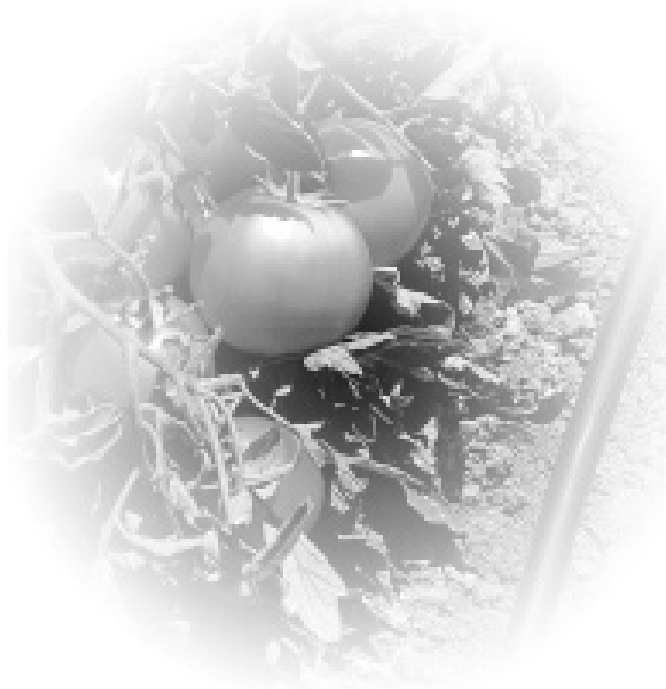

Pumps
Diesel Pumping Units
Propane Pumping Units
PTO Pumps
Rovatti PTO Irrigation Pump
PTO Slurry/Chopper Pumps
Pump Accessories
Couplers/Pipe/Hose

Screens & Fittings
Foot Valve Parts
Priming Valves
Primers
Generators
Murphy Switches
Hand Primers

Product	Description	Part Number	Weight	List Price
---------	-------------	-------------	--------	------------

SINGLE-STAGE ENGINE MOUNT PUMPS

BERKELEY

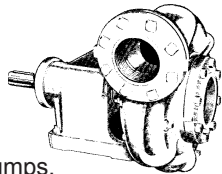

Pedestal Mount:

@ 2200 rpm

	GPM	PSI			
B3ZRM	250-850	60-45	-	120.0	Call
B3JRMBM	400-900	130-110	-	150.0	Call
B4JRMBH	600-1500	125-100	-	319.0	Call

*Call for other pumps.

Direct Mount:

@ 2000 rpm

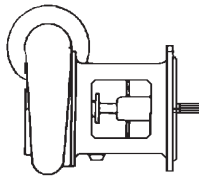

	GPM	PSI			
B3JQBM	300-850	110-85		365.0	Call
B4JQBH	450-1500	100-70		400.0	Call
B4EYQBH	500-1400	190-130		620.0	Call
B6JQBM	750-2250	100-70		475.0	Call

*Call for other pumps. Flywheel coupling NOT included.

CORNELL

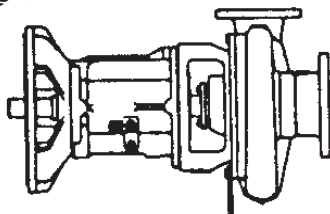

Direct Mount:

@ 2200 rpm

	GPM	PSI			
4RB	300-1500	95-65		520.0	Call
5RB	400-2200	104-70		715.0	Call
6RB	750-4000	100-75		815.0	Call
3HA	300-900	140-115		615.0	Call
5HH	300-1400	120-95		695.0	Call
6HH	1200-3600	155-120		845.0	Call

*Call for other pumps. Flywheel coupling included.

*6HH is rated at 2000 rpm.

*Cornell pumps work well at 3,000 gpm's & higher.

SLURRY & CHOPPER ENGINE MOUNT PUMPS

CORNELL-SLURRY

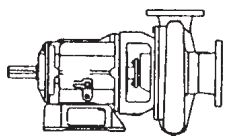

@ 2000 rpm

	GPM	PSI			
3HM	0-800	140-100	-		Call
4x4x14T	300-1500	130-100	-		Call

*3HM has an open impeller & therefore will handle stringy material

*4x4x14T has a 2-port impeller & therefore will not handle stringy material. (Excellent for hog manure)

DODA-CHOPPER



@ 2000 rpm

	GPM	PSI	HP		
27 PD	300-900	72-10	37-54	-	Call
35 PD	300-1300	120-38	80-115		Call

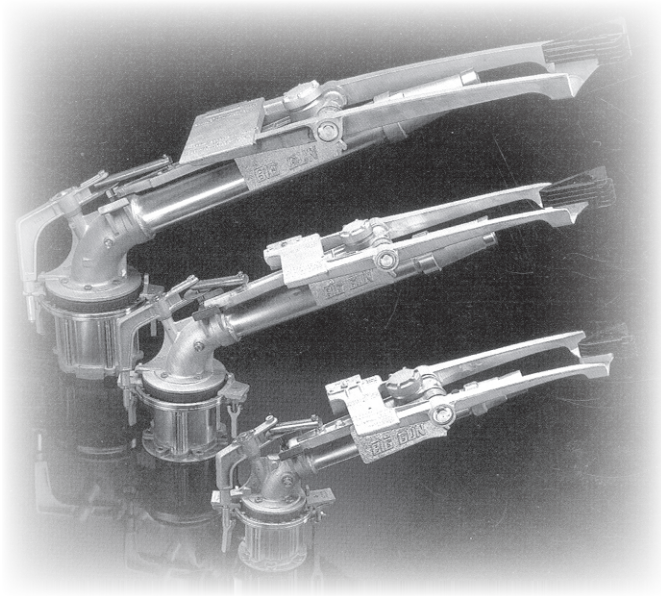

Always Open...
SchumacherIrrigation.com
Your Irrigation Superstore

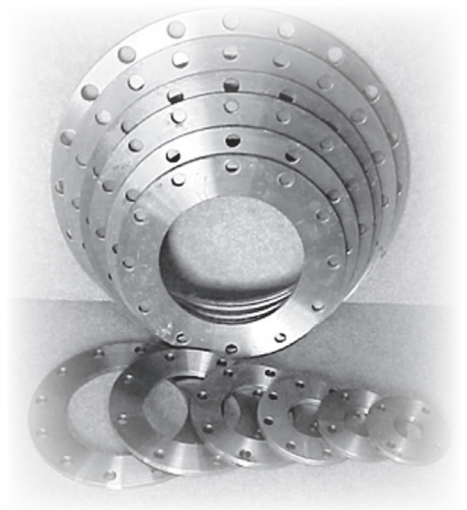

FLOATING PUMPS

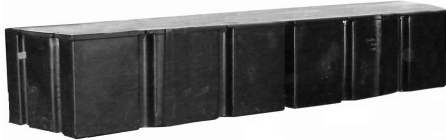

Product	Description	Part Number	Weight	List Price
FLOATS 	Float Capacity (lbs)			
	24"x36"x12"	335	9-6918	32.0 98.00
	24"x48"x12"	490	9-6919	32.0 107.00
	36"x48"x12"	470	9-6920	34.0 142.00
	24"x48"x16"	700	9-6921	41.0 120.00
	24"x36"x18"	600	9-6922	35.0 120.00
	24"x48"x18"	650	9-6923	41.0 132.00
	36"x48"x18"	1000	9-6924	52.0 188.00
	24"x48"x24"	900	9-6925	50.0 188.00

- * Thick-walled Molded Polyethylene Shell
- * Encapsulated Expanded Polystyrene Foam
- * 12 Year Warranty

FLOATING PUMPS TURBI-FLOAT®

Floating Pumps

CALL



Applications:

- Irrigation
- Municipal
- Industrial
- Commercial

Group No.	Discharge Body	GPM	PSI
One	4"	100-525	61-26
Two	4"	100-525	94-10
Three	6"	400-1100	20-11
Four	6" & 8"	400-1200	67-23
Five	4" & 6"	400-1100	135-48
Six	8" & 10"	1100-3250	33-7
Seven	8"	1100-1750	93-28
Eight	10"	2250-3250	14-6
Nine	10"	2300-4000	63-32



Pump shown with optional wheel kit, which adds to the versatility and user-friendly qualities of the Turbi-Float® system. Further enhances installation and removal for service and site transfers, often eliminating the need for lifting equipment.

Product	Description	Part Number	Weight	List Price
---------	-------------	-------------	--------	------------

DIESEL IRRIGATION PUMPING UNITS

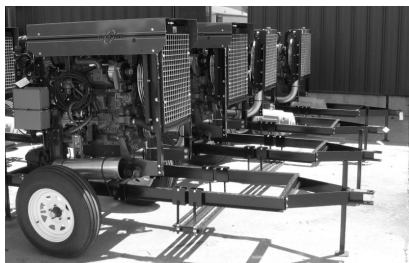

Model	Engine	Pump	@2000 rpm		List Price
			GPM	PSI	
John Deere	4045T	B4JQBH	400-1500	104-70	Call
John Deere	4039T	B3JQBM	300-860	108-78	Call
John Deere	6059T	B4JQBH	400-1500	104-70	Call
John Deere	6059T	B6JQBM	750-2250	104-70	Call



Horsepower Chart

MODEL	RPM						CONSUMPTION	SIZE	WEIGHT
	1800	2000	2100	2200	2300	2400			
4039D	57	62	65	67	67	67	.357 @ 1800	SAE4-10	1250
4045D	64	67	71	71	73	74	.347 @ 1800	SAE4-10	1300
4039T	76	82	84	85	88	88	.340 @ 1800	SAE4-10	1350
6059D	84	90	93	96	98	100	.350 @ 1800	SAE3-11	1400
4045T	88	92	93	94	95	96	.342 @ 1800	SAE4-10	1500
6068D	95	102	106	108	111	111	.345 @ 1800	SAE3-11	1500
6059T	112	121	126	128	133	135	.336 @ 1800	SAE3-11	1600
6068T	135	143	145	146	147	147	.344 @ 1800	SAE3-11	1650
6076T	165	165	165	165	--	--	.343 @ 1800	SAE3-11	2100
6076A	206	206	206	206	--	--	.337 @ 1800	SAE2-11	2200
6619A	242	244	246	--	--	--	.353 @ 1800	SAE1-11	2800

UNITS INCLUDE:

- Engine
- Pump
- Radiator
- Core Guard
- Electric Start (complete w/cables)
- Cables
- Battery Box (without battery)
- Fuel Lift Pump
- 15' Fuel Line
- Standard Duty Air Cleaner
- Muffler
- Mounting Feet
- Vernier Throttle Control & Panel
- OFF Highway Trailer w/USED tires.
- Water Level Safety Switch (L-150)
- Loss of Prime Switch (20PW7)
- Exhaust Primer
- Flywheel Coupling
- Suction Flange (if required)
- Discharge Priming Valve
- Discharge Adapter
- Pressure Gauge
- Suction Adapter
- Dresser Coupler
- Suction Pipe
- Foot Valve w/screen

OPTIONS:

- Skid Mount
- Battery
- Fuel Tank (30, 62 or 125 gallon)
- Extra Axle
- Screwjack for trailer

Pumps & Accessories

PTO PUMPS



Product	Description	Part Number	Weight	List Price
---------	-------------	-------------	--------	------------

PTO IRRIGATION PUMPS

CAPRARI



Gear Driven



D2/40	540	2"x2"	50-150	146-133	8-0221	200.0	Call
D2/50	540	2"x3"	50-250	135-121	8-0222	215.0	Call
D3/50	540	2"x3"	70-300	170-133	8-0223	230.0	Call
D2/65	540	4"x4"	100-450	107-97	8-0224	360.0	Call
D3/65	540	4"x4"	150-500	161-136	8-0225	270.0	Call
D2/80	540	5"x4"	200-700	110-99	8-0227	275.0	Call
DO4/80	540	5"x4"	200-700	167-143	8-0228	380.0	Call
DMR80 3/2	540	5"x4"	200-800	192-140	8-0230	400.0	Call
D03/100	540	4"x6"	400-1000	116-103	8-0232	365.0	Call
D01/125	540	8"x5"	500-1400	37-21	8-0234	430.0	Call

Make Schumacher Irrigation your;
 irrigation and liquid handling
 solutions provider with our quality
Custom Built fittings.

ROVATTI PTO IRRIGATION PUMP

Product Description Part Number Weight List Price

ROVATTI IRRIGATION PUMP

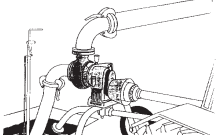
	Model	Drive Shaft	RPM	Inlet/Outlet	GPM	PSI	HP	Part Number	Weight	
 <p>TOF-50</p>  <p>Gear Driven</p>	*T0F-50	--	540	2"x2"	25-130	76-69	9-10	8-0235	45.0	Call
	T1-40-E	R300/90	540	2-1/2"x1-1/2"	50-130	150-140	13-20	8-0236	220.0	Call
	T2-40-E	R300/90	540	2-1/2"x1-1/2"	50-130	182-176	21-31	8-0237	255.0	Call
	T1-65-A-E	R300/90	540	2-1/2"x2"	100-260	88-80	12-19	8-0238	215.0	Call
	T1-50-E	R300/90	540	2-1/2"x2"	100-260	129-119	19-29	8-0239	240.0	Call
	T2-50-E	R300/90	540	2-1/2"x2"	100-330	149-125	24-39	8-0240	240.0	Call
	T2-65-E	R300/90	540	2-1/2"x2"	100-210	159-135	24-35	8-0241	250.0	Call
	T2-80-E	R300/90	540	3"x2-1/2"	160-460	101-86	18-32	8-0242	240.0	Call
	T2-85-E	R450/90	540	3"x2-1/2"	160-530	120-102	25-43	8-0243	250.0	Call
	T3-80A-E	R450/90	540	3"x2-1/2"	160-460	175-165	38-66	8-0244	300.0	Call
	T3-100A-E	R450/90	540	4"x3"	260-790	111-85	33-55	8-0245	290.0	Call
	T3-110-E	R600/90	540	4"x3"	260-920	134-108	46-83	8-1425	300.0	Call
	T4-100-E	R800/90.1	540	4"x3"	260-790	181-143	61-96	8-0246	375.0	Call
	T4-125-E	R800/90.1	540	5"x4"	530-1060	125-110	65-90	8-0248	375.0	Call

*T0F-50 is mounted directly to tractor without drive shaft or cart.

PUMP PERFORMANCE

These rugged, high performance power-take-off (PTO) irrigation pumps are inexpensive and designed for easy mobility. Their unique water-cooled gearbox allows the gearbox oil to be kept at a constant low temperature. This important feature reduces gasket damage due to high oil temperatures.

The heavy-duty pump frame and dynamically balanced impeller is made of durable cast iron construction. A graphic rope packing seal provides shaft lubrication. A heavy-duty, bowed axle 2-wheel cart allows for easy mobility. Standard pump discharge is horizontal, but can be rotated vertically. 540 & 1000 rpm models are available.

PTO pumps are ideal for irrigators who do not want to maintain yet another engine on their farm. In addition to irrigation, these pumps are designed for a wide range of applications including water transfer, wash-down, tank filling, etc. These durable PTO pumps will give years of dependable service at affordable prices.

Features:

- Oversized bearings
- Replaceable wear ring
- 540 & 1000 rpm speeds
- Finest grade of cast iron for high efficiency
- Unique water-cooled gearbox for extended gear life
- Two-wheel cart for easy positioning and transport

PTO Pump Performance Table																										
Model	GPM	25	50	70	80	90	100	120	130	160	190	210	240	260	330	400	460	530	660	790	920	1060	Suction	Discharge		
*T0F-50	PSI	76	76	76	75	74	73	72	69															2"	2"	
	HP	9	9	9	9	9	9	9	9																	
T1-40-E	PSI	150	149	148	147	145	143	140																2-1/2"	1-1/2"	
	HP	13	14	15	16	18	19	20																		
T2-40-E	PSI	182	181	181	180	179	178	176																	2-1/2"	1-1/2"
	HP	21	22	24	26	28	29	31																		
T1-65A-E	PSI								88	88	88	88	87	85	83	80									2-1/2"	2"
	HP								12	13	13	14	16	17	18	19										
T1-50-E	PSI						129	129	129	128	127	125	122	119											2-1/2"	2"
	HP						19	20	21	23	25	26	28	29												
T2-50-E	PSI						149	149	149	148	147	145	143	141	125										2-1/2"	2"
	HP						24	25	26	28	30	32	33	35	39											
T2-65-E	PSI						159	158	157	153	146	135													2-1/2"	2"
	HP						24	25	27	30	32	35														
T2-80-E	PSI									101	101	101	100	100	97	93	86								3"	2-1/2"
	HP									18	20	21	22	24	27	29	32									
T2-85-E	PSI									120	120	120	119	118	115	110	102								3"	2-1/2"
	HP									25	26	28	30	32	35	39	41	43								
T3-80A-E	PSI									175	175	175	175	173	170	165									3"	2-1/2"
	HP									38	40	42	44	46	53	60	66									
T3-100A-E	PSI													111	111	109	107	104	94	85					4"	3"
	HP													33	36	39	43	46	51	55						
T3-110-E	PSI													134	133	133	132	131	128	121	108				4"	3"
	HP													46	50	55	59	63	70	77	83					
T4-100-E	PSI													181	180	180	178	175	166	143					4"	3"
	HP													61	66	70	74	79	90	96						
T4-125-E	PSI																	125	124	122	118	110			5"	4"
	HP																	65	72	79	85	90				
	GPM	25	50	70	80	90	100	120	130	160	190	210	240	260	330	400	460	530	660	790	920	1060				

Pumps & Accessories

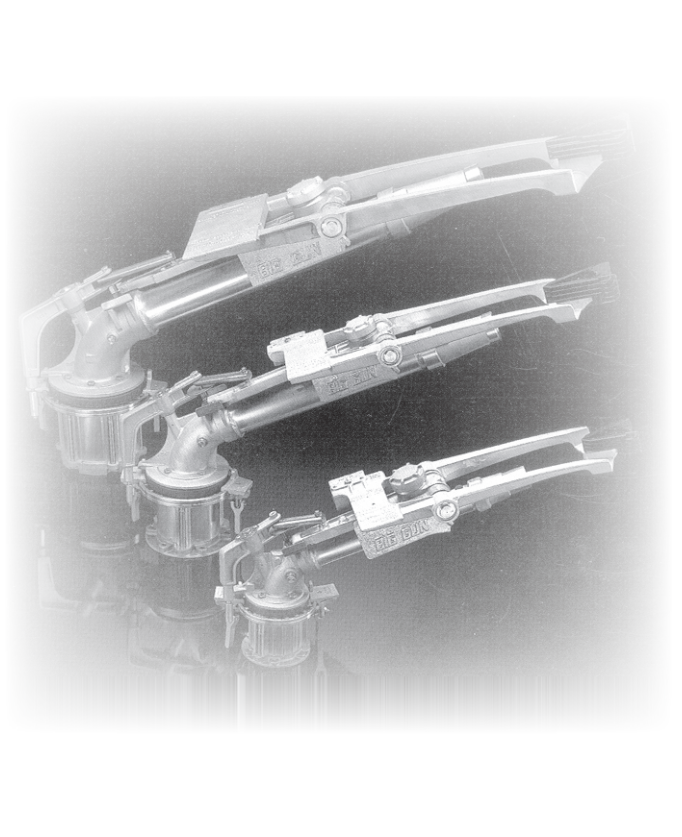

Product	Description	Part Number	Weight	List Price
PTO CHOPPER PUMPS				

Model	RPM	HP Req.	GPM	PSI	Part Number	List Price
-------	-----	---------	-----	-----	-------------	------------

DODA-CHOPPER

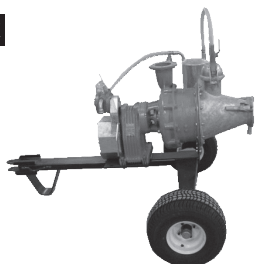

AFI-L27	540	40-60	300-900	80-20	8-0252	Call
AFI-L27	540	72-105	300-1000	130-55	8-0253	Call
AFI-L27	1000	135-165	300-700	210-175	8-0254	Call
AFI-L35	540	90-130	400-1300	135-55	8-0255	Call
AFI-L35	1000	130-170	400-1300	175-80	8-0256	Call

*Ideal for cattle manure with straw & hay
*Mechanical seal.
*AFI-L20 does not have a cutter blade

ROVATTI-CHOPPER



TL2-85GA w/TC85	540	24-39	158-475	114-102	8-0268	Call
TL3-80GA w/TC80	540	37-53	158-343	172-156	8-0269	Call
TL3-110GA w/TC110	540	40-64	317-924	127-81	8-0270	Call
TL4-100GA w/TC100	540	62-94	264-686	183-156	8-0271	Call
TL4-100GA w/TC100	1000	62-94	264-686	183-156	8-0272	Call

*Ideal for hog manure & light dairy.
*Mechanical seal.

The Rovatti chopper/slurry pumps are high-pressure pumps with a unique "bolt-on" chopper system. These units are ideal to effectively transport your manure slurry to the application site. The rotating chopper blade will cut and shred straw and other solids to small particles suitable for pumping and spraying through a volume sprinkler. They will run at much lower horsepower requirements their competitors. For example the TL3-110GA at 540rpm requires only 41 to 64 horsepower, while the comparable Doda DAF1-L27 at 540rpm requires 72 to 105 horsepower.

Features:

- Lubricated chopper shaft bushings
- Chopper shaft shear pins to reduce risk of damage to the shaft and impeller
- Special permanently lubricated mechanical seal for longer life
- Oversized bearings
- Replaceable wear ring
- 540 & 1000 rpm speeds
- Finest grade of cast iron for high efficiency
- Unique water-cooled gearbox for extended gear life
- Two-wheel cart for easy positioning and transport

Optional Equipment Includes:

- Automatic priming system which enables you to pump in as little as 15 seconds
- Quick Couplings for fast and easy pipe or hose hookup

Model	GPM	50	100	150	200	250	300	350	400	500	600	700	800	900	1000
TL2-85GA	PSI	112	113	114	114	114	113	111	109						
	HP	20	21	24	28	31	34	36	39						
TL3-80GA	PSI	173	173	172	171	170	163	155							
	HP	32	35	37	41	45	49	53							
TL3-110GA	PSI	126	127	128	129	129	129	127	124	119	112	106	97	84	65
	HP	30	32	34	36	37	40	43	44	48	52	56	60	63	64
TL4-100GA	PSI	184	184	183	183	182	181	179	178	173	166	153			
	HP	48	52	56	59	62	66	70	72	80	87	94			

*will handle solids

Product	Description	Part Number	Weight	List Price
---------	-------------	-------------	--------	------------

ELECTRIC MOTOR PUMPS

BERKELEY



Single Phase or Three Phase

Call



CORNELL

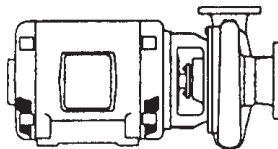

Single Phase or Three Phase

Call



Submersible Pumps

GOULDS/BERKELEY



- motor & pump comes disassembled.
- requires a panel box on single & three phase and a control box on single phase.
- heavy duty check valves required on all submersible pumps
- longer wire will be needed to connect to above ground panel.

Call

Rubber Expansion Joints

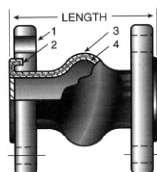

Single Sphere, 4"	6-8031	18.3	128.00
Single Sphere, 6"	6-8032	26.8	195.00
Single Sphere, 8"	6-8033	40.6	285.00
Single Sphere, 10"	6-8034	56.6	430.00
Single Sphere, 12"	6-8035	83.0	545.00
Double Sphere, 4"	6-8036	20.3	170.00
Double Sphere, 6"	6-8037	29.5	270.00
Double Sphere, 8"	6-8038	43.8	290.00
Double Sphere, 10"	6-8039	64.1	615.00
Double Sphere, 12"	6-8040	95.0	710.00

*To accommodate pressure loads, relieve movement stress, reduce noise, isolate vibration, compensate for misalignments after system goes on stream and prolong the life of motive equipment.

Product	Description	Part Number	Weight	List Price
---------	-------------	-------------	--------	------------

Gasoline Pumps

Product	Description	Part Number	Weight	List Price
HONDA	3-1/2 hp, 1-1/2"	WH 15 X	48.5	1,125.00
	5 hp, 2"	WH 20 X	52.0	1,289.00
	5.5 hp, 2"	WMP 20 X	52.0	1,025.00
	8 hp 3"	WT 30 X	132.0	2,499.00
	11 hp 4"	WT 40 X	172.0	3,775.00



WH15X

- High Pressure, Centrifugal, Self-Priming 1.5" Pump
- East-Start Honda OHV Commercial Engine
- 115 gal./min. Capacity
- Lightweight Aluminum Case
- Cast Iron Volute and Impeller
- Easy Carry Handle



WH20X

- High Pressure, Centrifugal, Self-Priming 2" Pump
- Easy-Start Honda OHV Commercial Engine
- 134 gal./min. Capacity
- Lightweight Aluminum Case
- Cast Iron Volute and Impeller
- Easy Carry Handle



WMP20X

- Multi-Purpose, Centrifugal Self-Priming 2" Pump
- Easy-Start Honda OHV Commercial Engine
- 220 gal./min. Capacity
- Thermoplastic Pump Housing for Chemical Capability
- Full Frame Protection
- Isolation Mounted Engine and Pump
- Protected by Honda Oil Alert®

HONDA

GENERATORS & PUMPS



WT30X

- Heavy-Duty 3" Construction Trash Pump
- Easy-Start Honda OHV Commercial Engine
- Full Frame Protection
- 319 gal./min. Capacity
- Solid Handling Capability Up to 1 1/16"
- Easy, Quick Clean-Out Port
- Easy-Service Wear Plate
- Protected by Honda Oil Alert®



WT40X

- Heavy-Duty 4" Construction Trash Pump
- Easy-Start Honda OHV Commercial Engine
- Full Frame Protection
- 604 gal./min. Capacity
- Solid Handling Capability Up to 1 1/16"
- Easy, Quick Clean-Out Port
- Easy-Service Wear Plate
- Protected by Honda Oil Alert®
- Self Priming

*Call for other sizes and brands on these economical self-priming pumps.
*15' max. suction lift

Pumps & Accessories

Product

Description

Part Number

Weight

List Price



YOUR COMPLETE SUPPLY HOUSE FOR:

POWER UNITS ENGINES MOTORS PUMPS ENGINE & PUMP PARTS & FITTINGS

Please call for all of your pumping needs. Just let us know your psi and gpm requirements over the phone, and our computer software will quickly choose the most efficient pump for your conditions.

John Deere, Cummins, Perkins, Isuzu, Lister, Deutz and other engines provide quality, dependable service for irrigation use.

INSTALLATION
Suction Connection
Suction Lift

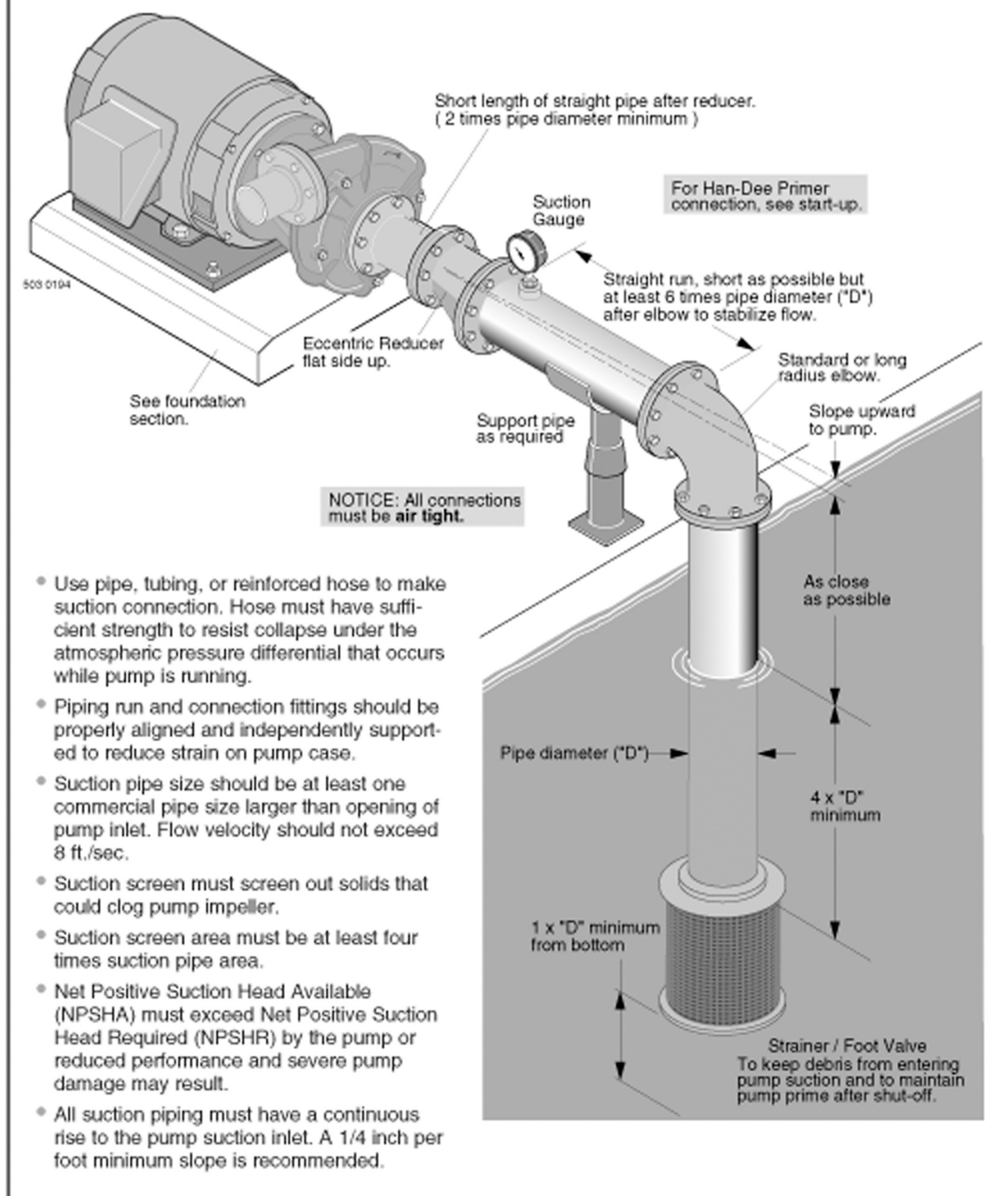

- Use pipe, tubing, or reinforced hose to make suction connection. Hose must have sufficient strength to resist collapse under the atmospheric pressure differential that occurs while pump is running.
- Piping run and connection fittings should be properly aligned and independently supported to reduce strain on pump case.
- Suction pipe size should be at least one commercial pipe size larger than opening of pump inlet. Flow velocity should not exceed 8 ft./sec.
- Suction screen must screen out solids that could clog pump impeller.
- Suction screen area must be at least four times suction pipe area.
- Net Positive Suction Head Available (NPSHA) must exceed Net Positive Suction Head Required (NPSHR) by the pump or reduced performance and severe pump damage may result.
- All suction piping must have a continuous rise to the pump suction inlet. A 1/4 inch per foot minimum slope is recommended.

Recommended



TYPE "B" SINGLE STAGE CENTRIFUGAL PUMP Bearing Frame Mount

CAST IRON IMPELLER
B3ZRM
Threaded Case (NPT)
Packing Construction
TABLE I

B/M No.	Rotation	Volute Case	Impeller	Impeller Diameter
B85480	CW	H00689	M11215	9.00"
B85483	CCW	H00698	M06852	9.00"

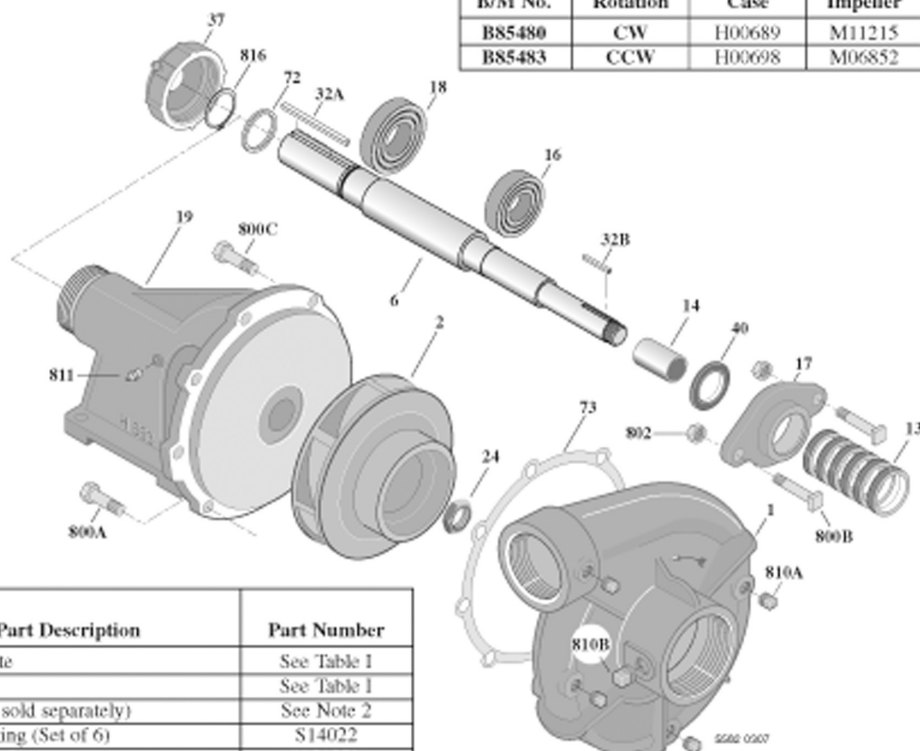

Item No.	Part Description	Part Number
1	Case, Volute	See Table 1
2	Impeller	See Table 1
6	Shaft (Not sold separately)	See Note 2
13	Ring, Packing (Set of 6)	S14022
14	Sleeve, Shaft	S05127L
16	Bearing, Ball	S13270
17	Gland, Packing (See Note 1)	S04948
18	Bearing, Ball	S13271
19	Frame	H00553
24	Locknut, Impeller (CW and CCW)	M10220
32A	Key, 1/4x2-1/8"	S24255
32B	Key, 3/16x1-1/4"	S34383
37	Outer Bearing Cap Assembly*	S19914
40	Slinger, Water	S12260
72	Ring, Thrust	S29218
73	Gasket, Volute	S05126
800A	Capscrew, Hex 3/8-16x7/8" (6 Req.)	S26825
800B	Bolt, Sq. Head 3/8-16x2-1/2" (2 Req.)	S23762
800C	Capscrew, Hex 3/8-16x1-1/8" (2 Req.)	S26827
802	Nut, Hex 3/8-16 (2 Req.)	S23343

* Includes grease fitting and set screw.

Item No.	Part Description	Part Number
810A	Plug, Pipe 1/4 NPT (4 Req.)	S23715
810B	Plug, Pipe 1/2 NPT	S23717
811	Fitting, Grease	S23670
816	Ring, Retaining	S23010

1. A two piece (split) stainless steel packing gland is available for replacement, order part number **B82468**.
2. **Shaft Replacement Kit** available for this model. Berkeley part number **B85540** for CW, **B85539** for CCW.
Pump Shaft sold in shaft replacement kit only.



TYPE "B" SINGLE STAGE
CENTRIFUGAL PUMP
Bearing Frame Mount

CAST IRON IMPELLER

B4JRMBH

Flanged Case

Packing Construction

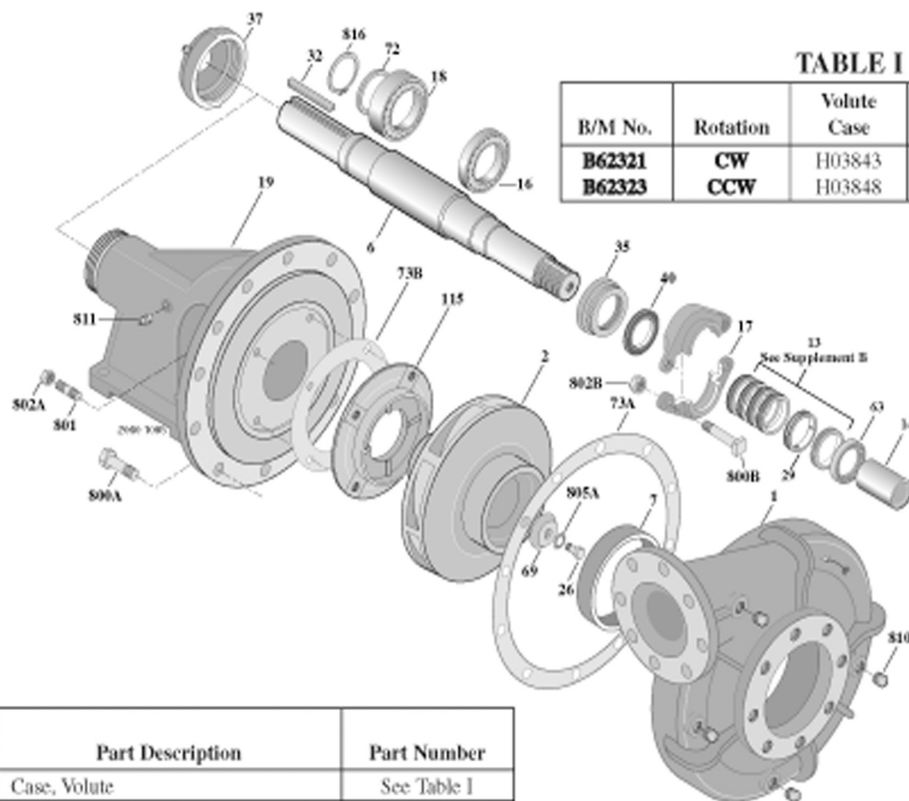

TABLE I

B/M No.	Rotation	Volute Case	Impeller	Impeller Diameter
B62321	CW	H03843	L05976	13.50"
B62323	CCW	H03848	L05974	13.50"

Item No.	Part Description	Part Number
1	Case, Volute	See Table I
2	Impeller	See Table I
6	Shaft (Not sold separately)	See Note 1
7	Ring, Wearing	S02894
13	Ring, Packing (Set of 4)	S13436
14	Sleeve, Shaft	S05974
16	Bearing, Ball	S15604
17	Gland, Packing	B82472
18	Bearing, Ball	S13396
19	Frame	H01599
26	Screw, Impeller 1/2-13x1-1/2"	S23623
29	Ring, Lantern	S18993
32	Key, 1/2x4"	S24214
35	Inner Bearing Cap	S05928
37	Outer Bearing Cap Assembly*	S35277
40	Slinger, Water	S10964
63	Bushing, Throat	S18992
69	Washer, Impeller	S19275
72	Ring, Thrust	S06519
73A	Gasket, Volute	S06271
73B	Gasket, Balance Ring	S09943
115	Ring, Balance	S12315

* Includes grease fitting.

Item No.	Part Description	Part Number
800A	Capscrew, Hex 5/8-11x1-1/2" (12 Req.)	S26999
800B	Bolt, Sq. Head 1/2-13x2-3/4" (2 Req.)	S23794
801	Stud, 3/8-16x1-3/8" (4 Req.)	S09942
802A	Nut, Hex 3/8-16 (4 Req.)	S23103
802B	Nut, Hex 1/2-13x7/16" (2 Req.)	S23347
805A	Washer, Lock	S23038
810	Plug, Pipe 1/2 NPT (4 Req.)	S23717
811	Fitting, Grease (2 Req.)	S23670
816	Ring, Retaining	S23016

- Shaft Replacement Kit** available for this model. Berkeley part number **B07596** for CW, **B07597** for CCW. Pump Shaft sold in shaft replacement kit only.

PUMP ACCESSORIES



Product	Description	Part Number	Weight	List Price
GLAND - BERKELEY 	Small	B3Z & B6Z	8-1000	118.00
	Large	B4J	8-1001	195.00

PACKING - BERKELEY 	Small - B3ZRM, B6ZRM	S-14022	8-0410	0.2	47.00
	Large - B3JQBM, B4JRM BH	S-13436	8-0412	0.7	76.00

PACKING - PULLER 	Packing Puller		8-0413		20.50
---	----------------	--	--------	--	-------

PACKING - BRAIDED	1/4" x 25' Box		9-6859		57.00
	5/16" x 18' Box		9-6860		49.00
	3/8" x 12' Box		9-6861		45.00

SUCTION ADAPTER

(GALVANIZED STEEL)



-Install with eccentric dip downward (as shown).

-Ball & sockets may be welded onto plain end

Thrd OD

2" x 3"	8-0430	2.9	50.00
3" x 4"	8-0431	4.0	60.00
4" x 5"	8-0432	6.0	70.00
4" x 6"	8-0510	7.0	85.00
4" x 8"	8-0511	12.7	110.00
5" x 6"	8-0512	7.6	110.00
5" x 8"	8-0513	12.6	130.00
6" x 6"	8-0514	12.1	90.00
6" x 8"	8-0515	14.1	125.00
6" x 10"	8-0517	19.3	165.00
8" x 8"	8-0516	16.3	180.00
8" x 10"	8-0518	19.8	260.00

DISCHARGE ADAPTER

(GALVANIZED STEEL)



Thrd Cplr

2" x 3"	8-0440	2.1	45.00
2" x 4"	8-0441	3.1	53.00
3" x 3"	8-0442	2.5	39.00
3" x 4"	8-0443	3.5	52.00
4" x 4"	8-0520	4.3	39.00
4" x 5"	8-0444	5.4	67.00
4" x 6"	8-0521	6.7	72.00
4" x 8"	8-0522	9.8	99.00
5" x 5"	8-0445	5.9	68.00
5" x 6"	8-0446	9.4	101.00
5" x 8"	8-0526	11.1	138.00
6" x 6"	8-0523	8.1	65.00
6" x 8"	8-0524	12.3	117.00
6" x 10"	8-0525	14.9	175.00

DRESSER COUPLERS, SUCTION PIPE

Product	Description	Part Number	Weight	List Price
DRESSER COUPLER - 6" LONG (POWDER COATED)	3" OD	8-0550	4.0	68.00
	4" OD	8-0551	5.5	81.00
	5" OD	8-0552	6.5	94.00
	6" OD	8-0553	7.5	105.00
	8" OD	8-0555	9.0	118.00
	10" OD	8-0556	12.0	166.00
	12" OD	8-0557	21.0	221.00

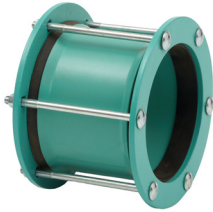

DRESSER COUPLER - 10" LONG (POWDER COATED)	Complete:	4" OD	8-0530	8.0	77.00
		5" OD	8-0536	11.0	95.00
		6" OD	8-0531	13.0	114.00
		8" OD	8-0532	16.0	129.00
		10" OD	8-0533	23.0	182.00
		12" OD	8-0534	27.0	250.00
	Body Only:	4"	6-2039	4.0	28.00
		5"	6-2040	4.0	38.00
		6"	6-2041	5.0	44.00
		8"	6-2042	7.0	47.00
		10"	6-2043	9.0	58.00
		12"	6-2044	11.0	86.00
	Flange Pack (Double):	4" OD	6-2021	4.0	49.00
	(for 10" long body)	5" OD	6-2022	7.0	57.00
		6" OD	6-2023	8.0	70.00
	8" OD	6-2024	9.0	82.00	
	10" OD	6-2025	14.0	124.00	
	12" OD	6-2026	16.0	164.00	

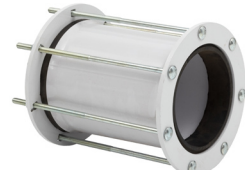
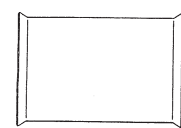
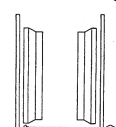
Product	Description	Part Number	Weight	List Price
SUCTION PIPE (ALUMINUM)	6" x 45° .058	8-0540	37.8	259.00
	6" x 90° .058	8-0541	37.8	299.00
	8" x 45° .072	8-0542	63.3	430.00
	8" x 90° .072	8-0543	63.3	475.00
	10" x 90° .094	8-0545	103.2	815.00

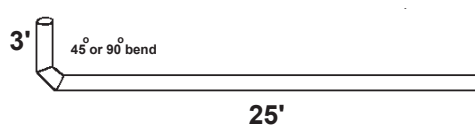

Product	ID	OD	Part Number	Weight	List Price
SUCTION BOOT (RUBBER)	6"	7"	8-0546	3.2	48.00
	8"	9"	8-0547	4.1	62.00
	10"	11"	8-0548	5.8	98.00
	12"	13-1/2"	8-0549	15.5	228.00



FOOT VALVE/SCREEN (CAST IRON)	1-1/2"	6-9603		24.00
	2"	8-0706	4.7	37.00
	2-1/2"	8-0707	6.6	51.00
	3"	8-0708	9.1	63.00
	4"	6-9604	16.5	105.00
	6"	6-9605	36.3	245.00
	8"	6-9606		468.00



Pumps & Accessories

INTAKE SCREENS & FITTINGS



Product	Description	Part Number	Weight	List Price
---------	-------------	-------------	--------	------------

SCREEN W/FOOT VALVE



3"	6-9844	7.0	197.00
4"	8-0709	11.0	236.00
5"	6-9845	14.0	318.00
6"	8-0710	17.0	390.00
8"	8-0711	26.5	555.00
10"	8-0712	46.0	945.00

*Foot Valve Drain Kit w/Cap 9-7666 **10.00**



* Use garden hose to drain suction line.

-0.050 Screen wall thickness
 -0.080 Screen available at additional cost
 -Standard holes are 1/4" round
 -Also available in 1/8" or 1/2" @ additional cost
 Other sizes are also available. Please call.

90° SUCTION ELBOW (CAST ALUMINUM)



4" x 90°	8-0719	7.0	149.00
6" x 90°	8-0720	10.5	226.00
8" x 90°	8-0721	14.5	347.00
10" x 90°	8-0722	23.0	545.00

45° SUCTION ELBOW (CAST ALUMINUM)



4" x 45°	8-0729	6.0	137.00
6" x 45°	8-0730	9.0	213.00
8" x 45°	8-0731	12.0	305.00
10" x 45°	8-0732	17.0	539.00

INTAKE STRAINER

-0.050 Screen wall thickness
 -Standard holes are 1/4" round
 -Also available in 1/8" or 1/2"
 @ additional cost



With slide:	4"	6-9793	3.5	58.00
	5"	6-9794	4.5	82.00
	6"	10 5/8" x 7 1/4"	6.0	98.00
	8"	16 1/2" x 9 1/4"	11.0	167.00
	10"	23" x 11 1/2"	15.0	223.00

Note: Intake strainers are smaller than Jumbo.