

# WAFER BUTTERFLY VALVES

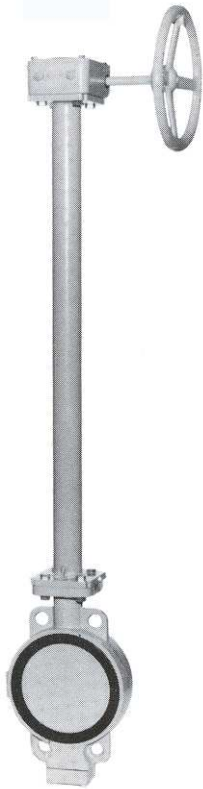

Product	Description	Part Number	Weight	List Price
---------	-------------	-------------	--------	------------

## WAFER BUTTERFLY VALVE WITH EXTENSION, GEAR



4" Gear w/24" ext.	6-9882	335.00
4" Gear w/36" ext.	6-9883	340.00
4" Gear w/48" ext.	6-9884	345.00
4" Gear w/60" ext.	6-9885	350.00
4" Gear w/72" ext.	6-9886	355.00
6" Gear w/24" ext.	8-1380	375.00
6" Gear w/36" ext.	8-1381	380.00
6" Gear w/48" ext.	8-1382	385.00
6" Gear w/60" ext.	8-1383	390.00
6" Gear w/72" ext.	8-1384	395.00
8" Gear w/24" ext.	8-1385	445.00
8" Gear w/36" ext.	8-1386	450.00
8" Gear w/48" ext.	8-1387	455.00
8" Gear w/60" ext.	8-1388	460.00
8" Gear w/72" ext.	8-1389	465.00
10" Gear w/24" ext.	8-1390	499.00
10" Gear w/36" ext.	8-1391	504.00
10" Gear w/48" ext.	8-1392	509.00
10" Gear w/60" ext.	8-1393	514.00
10" Gear w/72" ext.	8-1394	519.00
12" Gear w/24" ext.	8-1395	670.00
12" Gear w/36" ext.	8-1396	675.00
12" Gear w/48" ext.	8-1397	680.00
12" Gear w/60" ext.	8-1398	685.00
12" Gear w/72" ext.	8-1399	690.00



\* Measurements are from center of valve to top.  
 \* Note: Custom Lengths Available on request.  
 \* Call for pneumatic and electric actual wafer butterfly valves.

# WAFER BUTTERFLY VALVES

## WAFER BUTTERFLY VALVE WITH LEVER HANDLE



-Max 160 psi

2"	8-1351		69.00
2-1/2"	8-1352		74.00
3"	8-1353		90.00
4"	6-2050	16.0	106.00
5"	6-2055	22.0	140.00
6"	6-2051	24.0	150.00
8"	6-2052	41.0	195.00
10"	6-2053	63.0	275.00
12"	6-2054	92.0	375.00

## WAFER BUTTERFLY VALVE WITH GEAR HANDLE

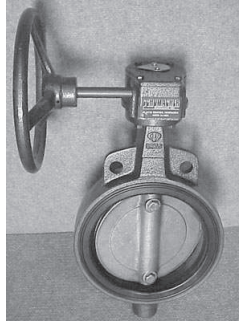

-Max 160 psi

2"	8-1354	19.0	140.00
2 1/2"	8-1355	20.0	145.00
3"	8-1356	21.0	155.00
4"	6-2056	24.0	165.00
5"	6-2057	29.0	195.00
6"	6-2058	26.0	205.00
8"	6-2059	37.9	275.00
10"	6-2060	55.5	329.00
12"	6-2061		500.00
14"	8-1205		1025.00
16"	8-1206		2715.00
18"	8-1207		2789.00
20"	8-1208		3750.00
24"	8-1209		6495.00

### Features:

- Perfect Shut Off liquid and gas in both directions
- Economic Alternatives to gate, ball and plug valves
- Corrosion Free - Stems and body are not in contact with the line media. Bodies are protected with epoxy coating.
- No Flange Gaskets for installation
- Self centering disc by axial movement due to the floating coupling
- Compact light weight wafer design (Flangeless Lug and U-Section)
- Anti Blow Out Stem - The upper stem is fully retained by the retainer plate under pressure in unlikely event of primary seal fail.
- Easy replaceable seat without any special tools
- Easy installation for each type of actuators; manual, pneumatic, hydraulic and electric
- Wide range of material for various conditions
- Maintenance Free
- Minimal flow loss and turbulence
- Reliable for flow control
- Self Cleaning
- Stainless steel disc and stem

### Features

- **Perfect Shut Off** - liquid and gas in both directions
- **Economic Alternatives** to gate, ball and plug valves
- **Corrosion Free** - Stems and body are not in contact with the media. Bodies are protected with epoxy coating.
- **No Flange Gaskets** for installation.
- **Self Centering Disc** - by axial movement due to the floating coupling
- **Compact Light Weight** wafer design (Flangeless Lug and U-Section)
- **Anti Blow Out Stem** - The upper stem is fully retained by the retainer plate under pressure in unlikely event of primary seal fail.

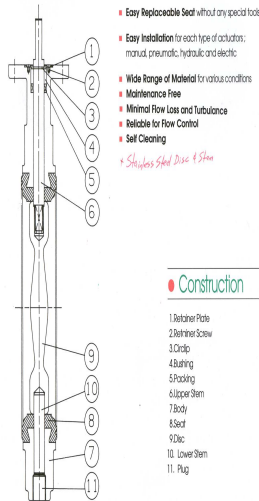

### Construction

1. Retainer Plate
2. Retainer Screw
3. Circlip
4. Bushing
5. Packing
6. Upper Stem
7. Body
8. Seat
9. Disc
10. Lower Stem
11. Plug

### Construction:

1. Retainer Plate
2. Retainer Screw
3. Circlip
4. Bushing
5. Packing
6. Upper Stem
7. Body
8. Seat
9. Disc
10. Lower Stem
11. Plug

Fittings



# WAFER BUTTERFLY VALVES



Product	Description	Part Number	Weight	List Price
---------	-------------	-------------	--------	------------

## SEAT, WAFER BUTTERFLY VALVE

\* Buna N Rubber  
 \* Specify make of valve when ordering

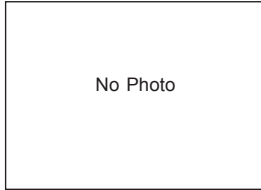

4"	9-6851	23.00
5"	9-6852	31.00
6"	9-6853	35.00
8"	9-6854	50.00
10"	9-6855	70.00
12"	9-6856	101.00
14"	9-6857	166.00

## WAFER BUTTERFLY VALVE WITH 2" SQ. NUT

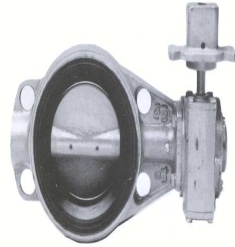

Gear	Part Number	Weight	List Price
2"	6-9630	74.94	189.00
2-1/2"	6-9631	76.88	192.00
3"	6-9632	78.83	202.00
4"	6-9633	93.16	165.00
5"	6-9634	98.30	200.00
6"	6-9635	78.38	210.00
8"	6-9636	96.56	275.00
10"	6-9637	153.13	330.00
12"	6-9638	253.09	434.00

## WAFER BUTTERFLY VALVE, PNEUMATIC



Wafer Butterfly Valve, Pneumatic, 2"	6-8072	995.00
Wafer Butterfly Valve, Pneumatic, 2-1/2"	6-8073	995.00
Wafer Butterfly Valve, Pneumatic, 3"	6-8074	995.00
Wafer Butterfly Valve, Pneumatic, 4"	6-8075	1159.00
Wafer Butterfly Valve, Pneumatic, 5"	6-8076	1439.00
Wafer Butterfly Valve, Pneumatic, 6"	6-8077	1479.00
Wafer Butterfly Valve, Pneumatic, 8"	6-8078	1919.00
Wafer Butterfly Valve, Pneumatic, 10"	6-8079	2495.00
Wafer Butterfly Valve, Pneumatic, 12"	6-8080	3289.00
Wafer Butterfly Valve, Pneumatic, 12" special	6-8081	2679.00

## WAFFER BUTTERFLY VALVE, ELECTRIC

\* 120 Volt AC  
 \* Also available in 24 volt DC Battery



Wafer Butterfly Valve, Electric, 2"	6-8082	1960.00
Wafer Butterfly Valve, Electric, 2-1/2"	6-8083	1970.00
Wafer Butterfly Valve, Electric, 3"	6-8084	1980.00
Wafer Butterfly Valve, Electric, 4"	6-8085	2070.00
Wafer Butterfly Valve, Electric, 5"	6-8086	2090.00
Wafer Butterfly Valve, Electric, 6"	6-8087	3240.00
Wafer Butterfly Valve, Electric, 8"	6-8088	3220.00
Wafer Butterfly Valve, Electric, 10"	6-8089	3495.00
Wafer Butterfly Valve, Electric, 12"	6-8090	3875.00

- 110/120 volt (call for 24 volt DC & 50 hz)
- Stainless steel disc
- 416 Stainless Steel Stem
- EPDM seat
- Stainless steel thrust washer
- Epoxy coated cast iron body

**T-WRENCH FOR 2" OPTIONAL NUT**



36" Long

6-9720

135.00

**ALFALFA VALVE STUB FOR PIP PVC & STEEL PIPE**

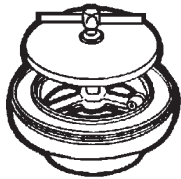

PIP PVC

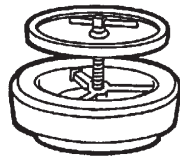

Steel

\*6" has solid arch, all others are removeable.

Material	Size	Part No.	Unit Price	Total Price
PIP PVC	*6"	6-2102	16.0	170.00
	8"	6-2103	24.0	239.00
	10"	6-2104	28.0	290.00
	12"	6-2105	39.0	350.00
Steel	*6"	6-2098	15.0	169.00
	8"	6-2099	23.0	175.00
	10"	6-2100	30.0	212.00
	12"	6-2101	42.0	255.00

**UNIVERSAL ALFALFA HYDRANT**

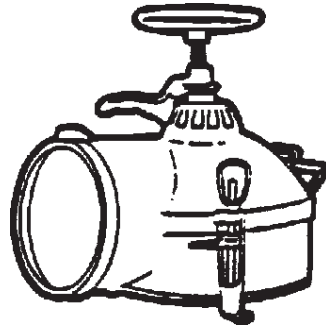

Call for other sizes.

Size	Part No.	Unit Price	Total Price
6" x 6"	6-2106	16.0	420.00
8" x 8"	6-2107	21.0	527.00
10" x 10"	6-2108	30.0	615.00
12" x 12"	6-2109	32.0	730.00

**STEM GATE VALVE, BRASS**

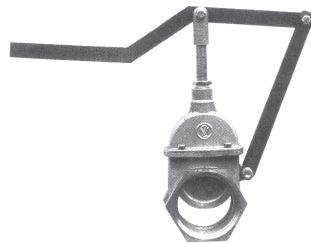

Size	Connection	Part No.	Unit Price	Total Price
4"	Threaded	6-9890		185.00
6"	Threaded	6-9891		349.00
4"	4-Bolt Flange	9-5472		305.00
6"	4-Bolt Flange	9-5473		369.00
8"	4-Bolt Flange	9-5474		649.00

Fittings

# VALVES & ACCESSORIES



Product	Description	Part Number	Weight	List Price
<b>ALUMINUM LOW PRESSURE VALVE</b>	6"	6-1460	10.0	159.00
	8"	6-1461	15.0	185.00
	10"	6-1462	20.0	227.00
	12"	6-8028		395.00

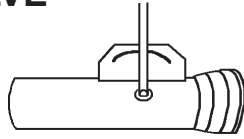

45 psi max pressure

<b>ALUMINUM LOW PRESSURE END TEE VALVE</b>	6"	6-1301	21.0	375.00
	8"	6-1302	27.0	430.00
	10"	6-1303	34.0	485.00

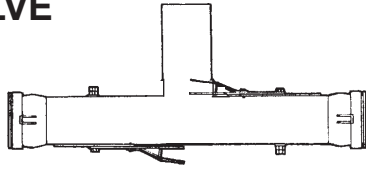

<b>PVC LOW PRESSURE VALVE</b>	6"	6-1356	--	225.00
	8"	6-1357	--	249.00
	10"	6-1358	--	306.00
	12"	6-1359	--	367.00

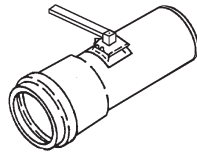

<b>LOW PRESSURE VALVE KIT</b>	6"	6-1473	--	95.00
	8"	6-1474	--	102.00
	10"	6-1475	--	139.00

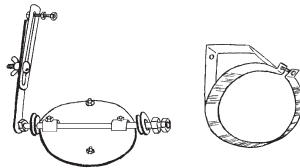

\* Instructions included

<b>RUBBER DISC FOR LOW PRESSURE VALVE</b>	6"	6-1013	--	29.00
	8"	6-1014	--	43.00
	10"	6-1367	--	52.00

<b>RUBBER, WASHER</b>	5/8"	6-1015	--	1.00
-----------------------	------	--------	----	------



<b>HYDRANT, WOODFORD</b>	*3/4" x 4'	6-1321	--	110.00
	*3/4" x 5'	6-1322	--	116.00
	1" x 4'	6-1323	--	175.00
	1" x 5'	6-1324	--	179.00

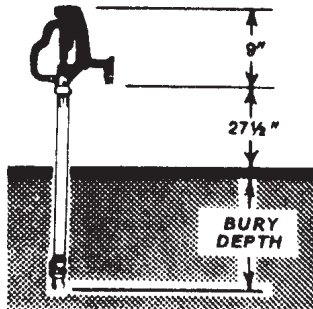

\*3/4" is standard garden hose connection

**SURGE GATE VALVE**

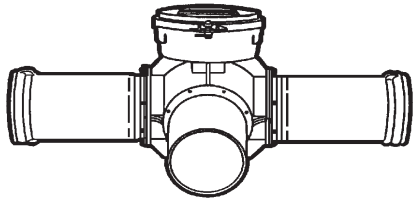

6"	6-1505	39.0	<b>2032.00</b>
8"	6-1506	46.0	<b>2232.00</b>
10"	6-1507	58.0	<b>2522.00</b>

**CHECK VALVE, RINGLOCK**

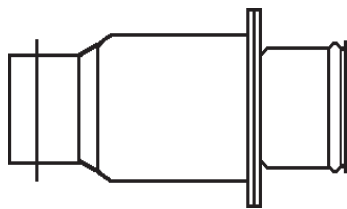

6"	6-1470	40.0	<b>275.00</b>
8"	6-1471	44.0	<b>335.00</b>
10"	6-1472	50.0	<b>390.00</b>

**BLACK CHECK VALVE - PLAIN X PLAIN**

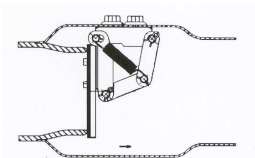
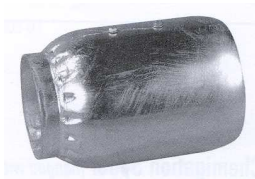

4"	6-1463	15.0	<b>150.00</b>
5"	6-1464	15.0	<b>153.00</b>
6"	6-1465	18.0	<b>145.00</b>
8"	6-1466	28.0	<b>180.00</b>
10"	6-1467	38.0	<b>200.00</b>
12" w/ 10" Body	6-1468	42.0	<b>315.00</b>

\*Galvanized or Epoxy-coated available at a nominal charge.

**CHECK VALVE, CAST ALUMINUM PLAIN X PLAIN**

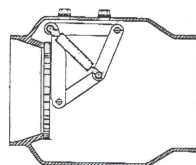

4"	6-9682	<b>165.00</b>
5"	6-9683	<b>185.00</b>
6"	6-9684	<b>220.00</b>
8"	6-9685	<b>250.00</b>
10"	6-9686	<b>270.00</b>

Fittings

Product	Description	Part Number	Weight	List Price
<b>CHECK VALVE, GAL. STEEL FLANGE X FLANGE</b>	4"	6-1710	30.0	242.00
	5"	6-1711	32.0	259.00
	6"	6-1712	34.0	266.00
	8"	6-1713	55.0	317.00
	10"	6-1714	79.0	415.00
	12" w/ 10" Body	6-1715	91.0	414.00
	12"	6-9751	140.0	2003.00
	14"	8-1346	220.0	1950.00
	16"	8-1347	325.0	2400.00
	20"	8-1348	400.0	2995.00
	22"	8-1349		3150.00
	24"	8-1350		4595.00

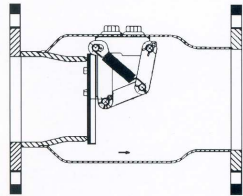

<b>CHECK VALVE, CAST ALUMINUM FLANGE X FLANGE</b>	4"	6-9687	295.00
	5"	6-9688	310.00
	6"	6-9689	350.00
	8"	6-9690	410.00
	10"	6-9691	565.00

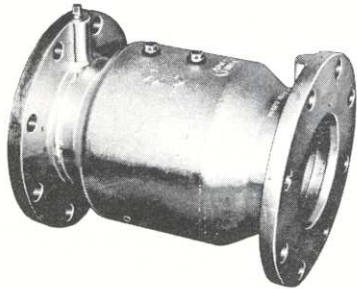

<b>CHECK VALVE - WAFER</b>	2"	8-1400	110.00
	2 1/2"	8-1401	122.00
	3"	6-1770	149.00
	4"	6-1771	175.00
	6"	6-1772	265.00
	8"	6-1773	360.00
	10"	6-1774	460.00
	12"	6-1775	680.00
	16"	8-1402	1822.00
	18"	8-1403	3935.00
	20"	8-1404	5186.00
	24"	8-1405	5900.00

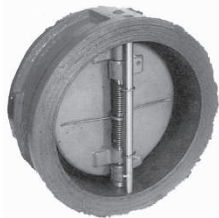

**CHECK VALVE**

Female Threaded 3"

8-1330

117.00



**COMBO VALVE, PLAIN**

130 maximum psi

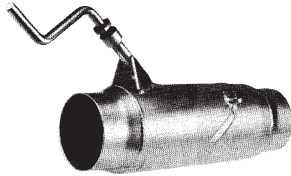

4"	6-1480	18.0	<b>230.00</b>
6"	6-1481	23.0	<b>295.00</b>
8"	6-1482	55.0	<b>380.00</b>
10"	6-1483	77.0	<b>520.00</b>
12"	6-1700	108.0	<b>675.00</b>

**COMBO VALVE, HOOK**

130 maximum psi

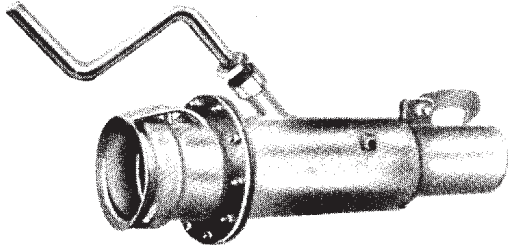

3"	6-1477	16.0	<b>295.00</b>
4"	6-1478	18.0	<b>285.00</b>
6"	6-1479	26.0	<b>349.00</b>
8"	6-1493	65.0	<b>445.00</b>
10"	6-1494	94.0	<b>535.00</b>

**COMBO VALVE, RINGLOCK**

130 maximum psi

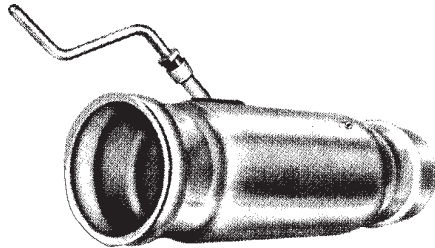

4"	6-1476	14.0	<b>260.00</b>
6"	6-1484	27.0	<b>319.00</b>
8"	6-1485	58.0	<b>425.00</b>
10"	6-1486	88.0	<b>595.00</b>
12"	6-1701	120.0	<b>720.00</b>

**COMBO VALVE, FLANGED**

130 maximum psi

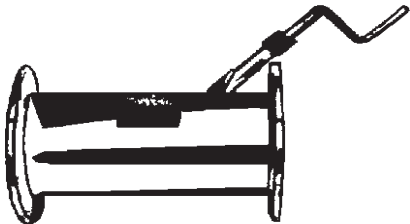

6"	6-1487	30.0	<b>369.00</b>
8"	6-1488	74.0	<b>475.00</b>
10"	6-1489	80.0	<b>629.00</b>
12"	6-1702	157.0	<b>785.00</b>

Fittings

# BUTTERFLY INLINE VALVE & TEE



Product	Description	Part Number	Weight	List Price
<b>BUTTERFLY INLINE VALVE, RINGLOCK</b>	6"	6-1440	19.0	<b>237.00</b>
	8"	6-1441	29.0	<b>338.00</b>
	10"	6-1442	43.0	<b>464.00</b>

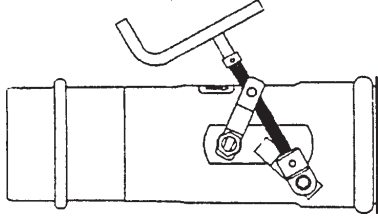

150 max. psi on 4", 6", & 8" valves  
80 max psi on 10" valves

## BUTTERFLY INLINE VALVE, HOOK

4"	6-1450	12.3	<b>207.00</b>
5"	6-1458	15.8	<b>260.00</b>
6"	6-1451	24.0	<b>255.00</b>
8"	6-1452	35.0	<b>346.00</b>
10"	6-1459	37.0	<b>520.00</b>

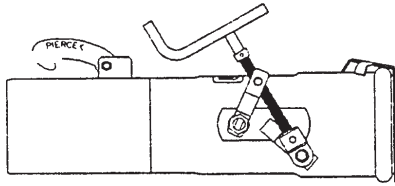

150 max. psi on 4", 6", & 8" valves  
80 max psi on 10" valves

## BUTTERFLY INLINE VALVE, PLAIN

4"	6-1453	11.8	<b>175.00</b>
5"	6-1454	13.5	<b>195.00</b>
6"	6-1455	19.5	<b>211.00</b>
8"	6-1456	31.5	<b>269.00</b>
10"	6-1457	36.0	<b>379.00</b>

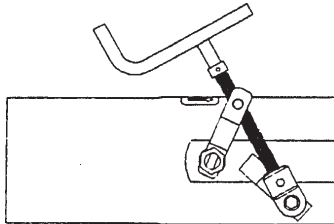

150 max. psi on 4", 6", & 8" valves  
80 max psi on 10" valves

## BUTTERFLY INLINE VALVE END TEE, HOOK

4"	6-1443	26.0	<b>310.00</b>
5"	6-1444	33.0	<b>368.00</b>
6"	6-1445	47.0	<b>555.00</b>
8"	6-1446	56.0	<b>895.00</b>

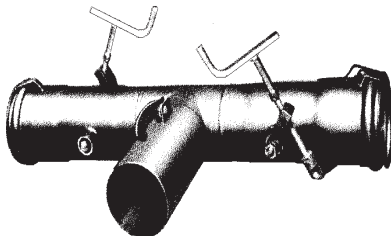

\*Also available in Ringlock  
\*Also available in Line Valve Tees.

150 max. psi on 4", 6", & 8" valves  
80 max psi on 10" valves

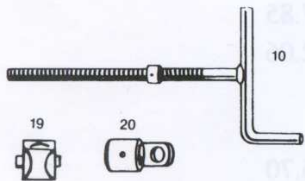
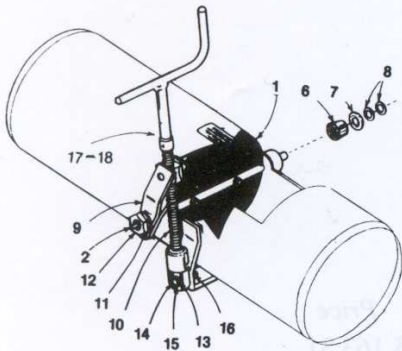

**PLATE & SPRING ASSEMBLY**

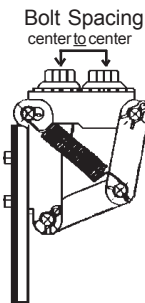

Part Name	Size	Item #	Part #	Price
<b>Disc, Inline</b>	4"	1	6-1495	22.00
	5"	1	6-1496	31.00
	6"	1	6-1497	29.00
	8"	1	6-1498	47.00
	10"	1	6-1499	91.00
<b>Shaft, Inline</b>	4"	2	6-4250	18.00
	5"	2	6-4251	24.00
	6"	2	6-4252	29.00
	8"	2	6-4253	31.00
	10"	2	6-4254	37.00
<b>Hex Bolt, Inline (req 2, 3 for 10")</b>	4"-5"	3	6-4255	0.95
	6"-8"	3	6-4256	1.50
	10"	3	6-4257	1.70
<b>Washer, Inline (req 2)</b>	4"-5"	4	6-4258	0.80
	6"-8"	4	6-4259	0.45
<b>Hex Nut, Inline (req 2)</b>	4"-5"	5	6-4260	0.50
	6"-8"	5	6-4261	0.65
<b>Chevron Gasket (req 2)</b>	4"-5"	6	6-4262	1.20
	6"-8"-10"	6	6-4263	2.10
<b>Washer, Reducer (req 4)</b>	4"-5"	7	6-4264	0.50
	6"-8"-10"	7	6-4265	0.75
<b>Retainer Ring (req 4)</b>	4"-5"	8	6-4266	1.25
	6"-8"-10"	8	6-4267	1.50
<b>Arm Linkage (req 2)</b>		9	6-4268	2.00
<b>Crank Assembly (includes 17, 18, 19, 20)</b>			6-4269	61.00
<b>Washer, Star</b>		11	6-4270	0.40
<b>Jam Nut</b>		12	6-4271	0.50
<b>Ferrule SS</b>		13	6-4272	.50
<b>Hex Bolt, Eg.</b>		14	6-4273	0.30
<b>Washer SAE</b>		15	6-4274	0.25
<b>Hex Nut, 3/8"</b>		16	6-4275	0.15
<b>Collar (req 2)</b>		17	6-4276	5.00
<b>Roll Pin (req 2)</b>		18	6-4277	0.80
<b>Stem &amp; Handle</b>		10	6-4278	23.00
<b>Thrust Nut</b>		19	6-4279	8.50
<b>Yoke</b>		20	6-4280	6.00

Brand	Size	Bolt Spacing	Part #	Price
<b>Clemons:</b>	4",5",6"	2-1/2"	6-1500	96.00
	8"	3"	6-1501	128.00
	10" (Travis)	4-1/2"	6-1502	150.00
<b>Pierce/Travis:</b>	4"	2"	6-1738	120.00
	6"	2-1/2"	6-1730	150.00
	8"	3-1/2"	6-1731	169.00
	10"	4-1/2"	6-1732	150.00
<b>Lake/Ames:</b>	4"	1-1/8"	6-1736	150.00
	5"	2-1/4"	6-1737	175.00
	6"	2-5/32"	6-1733	175.00
	8"	3"	6-1734	215.00
	10"	4-1/4"	6-1735	241.00
<b>Kroy:</b>	6"	3-1/2"	9-5425	147.00
	8"	3-1/2"	9-5426	169.00
	10" (Travis)	3-1/2"	9-5427	205.00
<b>Springs Only</b>	4", 6", 8", 10"		9-6858	10.00

Fittings

**CHEMIGATION VALVES FERTILIZER ACCESSORIES**



Product	Description	Part Number	Weight	List Price
<b>CHEMIGATION VALVE, RINGLOCK</b>	4"	9-6826		<b>426.00</b>
	6"	6-1401	40.0	<b>610.00</b>
	8"	6-1402	45.0	<b>730.00</b>
	10"	6-1403	50.0	<b>990.00</b>
	12"	9-6829		<b>1799.00</b>

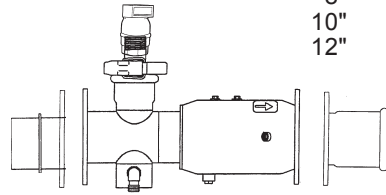

Includes: 2" ARV, 3/4" nuts & bolts, flange gaskets

<b>CHEMIGATION VALVE, FLANGE X COUPLER</b>	4"	9-6824		<b>379.00</b>
	6"	6-1360	50.0	<b>524.00</b>
	8"	6-1361	55.0	<b>620.00</b>
	10"	6-1362	60.0	<b>843.00</b>
	12"	9-6827		<b>1660.00</b>

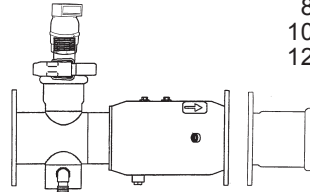

Includes: 2" ARV, 3/4" nuts & bolts, flange gaskets

<b>CHEMIGATION VALVE, FLANGE X FLANGE</b>	4"	9-6825		<b>332.00</b>
	6"	6-1370	45.0	<b>425.00</b>
	8"	6-1371	50.0	<b>510.00</b>
	10"	6-1372	55.0	<b>695.00</b>
	12"	9-6828		<b>1450.00</b>

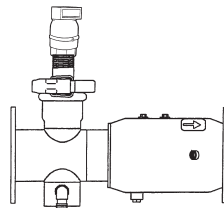

Includes: 2" ARV, & flange gaskets

<b>FLANGE ADAPTERS, STEEL GALVANIZED</b>	4" Flange x FRL	9-6830		<b>36.00</b>
	6" Flange x FRL	6-6450		<b>84.00</b>
	8" Flange x FRL	6-6451		<b>95.00</b>
	10" Flange x FRL	6-6449		<b>113.00</b>
	12" Flange x FRL	6-6448		<b>140.00</b>

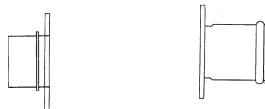

	4" Flange x MRL	9-6831		<b>36.00</b>
	6" Flange x MRL	6-6459		<b>84.00</b>
	8" Flange x MRL	6-6549		<b>95.00</b>
	10" Flange x MRL	6-6458		<b>112.00</b>
	12" Flange x MRL	6-6457		<b>139.00</b>

<b>MISTER MIST'R INJECTION VALVE</b>	6-1523	0.5	<b>48.00</b>
--------------------------------------	--------	-----	--------------



\*15 psi release is standard (optional 9, 25, 65 or 80 psi available.)

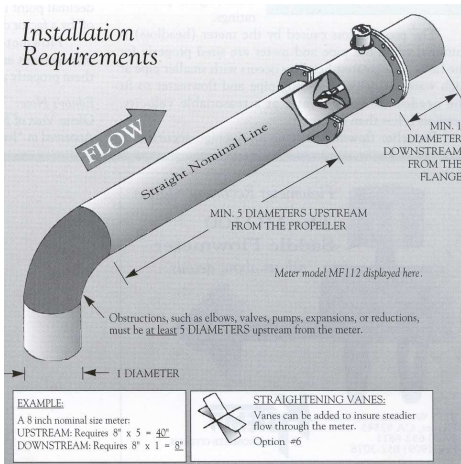

**Without Straightening Vanes:**

Install at least **10** times the diameter downstream from valves, elbows, cooling coils, tees, reducers, increasers, & other obstructions.

**With Straightening Vanes:**

Install at least **5** times the diameter downstream from valves, elbows, cooling coils, tees, reducers, increasers, & other obstructions.

**BOLT-ON WATER METER - MCCROMETER**

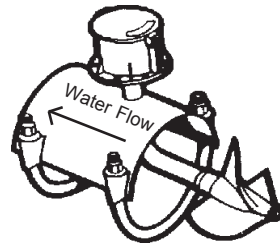

	Drill Size	GPM			
4" OD / PIP	4"	50-600	6-1930	14.0	<b>1159.00</b>
6" OD / PIP	5"	90-1200	6-1931	19.0	<b>1226.00</b>
8" OD / PIP	5-1/8"	100-1500	6-1932	21.0	<b>1295.00</b>
10" OD / PIP	6"	125-1800	6-1933	23.0	<b>1350.00</b>
12" OD / PIP	7"	150-2500	6-1934	30.0	<b>1450.00</b>

-Above include an overrun bearing.  
-State wall thickness & O.D. when ordering.  
-+ or - 2% Accuracy

**WATER METER, FEMALE PIPE THREAD**

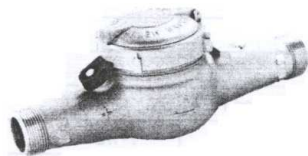

3/4"	6-9693	<b>305.00</b>
1"	6-9694	<b>252.00</b>
1-1/2"	6-9695	<b>510.00</b>
2"	6-9696	<b>495.00</b>

Included are 2 female thread couplings

**WATER METER FLOW TUBE, POWDER COATED (26" LONG)**



**Plain x Plain(weld on):**

4"	od, plain x plain, w/vanes	9-5295	<b>121.00</b>
6"	od, plain x plain, w/vanes	9-5296	<b>145.00</b>
8"	od, plain x plain, w/vanes	9-5297	<b>173.00</b>
10"	od, plain x plain, w/vanes	9-5298	<b>215.00</b>



**Flange x Flange:**

4"	flange x flange, w/vanes	9-5299	<b>200.00</b>
6"	flange x flange, w/vanes	9-5300	<b>242.00</b>
8"	flange x flange, w/vanes	9-5301	<b>290.00</b>
10"	flange x flange, w/vanes	9-5302	<b>349.00</b>

-26" long  
-includes straightening vanes

Fittings

Product	Description	Part Number	Weight	List Price
<b>BOLT-ON WATER METER - MCCROMETER (REVERSE IMPELLER)</b>				

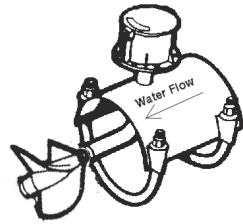

4"	8-1431	1275.00
6"	8-1432	1350.00
8"	8-1433	1425.00
10"	8-1434	1495.00
12"	8-1435	1565.00

For Liquid waste manure  
Overrun Bearing Included

**STRAIGHTENING VANES, FOR WATER METERS**

Aluminum , Weld-In

OD Pipe Size



Steel , Weld-In

OD Pipe Size

4"	9-6868	37.00
6"	9-6869	39.00
8"	9-6870	42.00
10"	9-6867	51.00

4"	9-6877	47.00
6"	9-6878	56.00
8"	9-6879	93.00
10"	9-6876	74.00

Steel , Bolt-On

OD Pipe Size



4"	9-6873	71.00
6"	9-6874	80.00
(Stainless Steel) 8"	9-6875	88.00
10"	9-6871	111.00
12"	9-6872	115.00

**STRAIGHTENING VANE, FLOW STRAIGHTENER, (BOLT-ON)**

OD Pipe Size

6"	9-6880	788.00
8"	9-6881	840.00
10"	9-6882	925.00



IPS Pipe Size

6"	9-6883	788.00
8"	9-6884	840.00
10"	9-6885	925.00

Outside body is NOT included in price.  
Flow straightener is a cone-shaped device that sits upstream from the meter and conditions the fluid to remove flow irregularities prior to measurement. The conditioned flow supports high accuracy flow measurement and virtually eliminates the need for space-consuming, costly upstream/downstream straight-pipe runs.